

KOMI

sterdil®



MOBILE COLUMN LIFT

ST 1075

Capacity 16,500 lbs.



STERDIL
SUPERIOR SOLUTIONS BY
QUALITY PEOPLE

Superior solutions by quality people



The Stertil Group provides customized and technically advanced lifting solutions for heavy-duty customers worldwide, as well as the best possible after-sales service from factory trained local partners. These superior solutions are conceived, developed and implemented by a team of specialized professionals with unique experience. Thanks to its quality people, its total in-house production process and its international organization, Stertil-Koni is the world leader in the field of heavy-duty vehicle lifting systems.

Wireless...

Our wireless mobile column lifts with the ebright Smart Control System represent the latest in mobile column lifting technology. Using the innovative ID key, you can connect up to 32 columns in a single lift set. In most cases, the special deep cycle batteries only need to be recharged every two weeks. No time is wasted connecting up cables and the mechanic has maximum access to the vehicle, without any tripping hazards.

... or cabled, it's up to you

If you predominantly work in a fixed location the cabled mobile column lifts could be the best solution for you. This setup offers the possibility to connect up to 28 columns in a single lift set. All interconnection cables are equipped with heavy-duty plugs at both ends. Optional extra strong drive-over interconnection cables are available to provide protection against damage.

Wireless mobile column lifts with **ebright Smart Control System**



TOUCH
SCREEN



WIRELESS



Superior control for cabled version

Both the wireless and the cabled column lifts are equipped with a control panel on each individual column. Columns can be operated individually, in pairs or simultaneously as a complete set with the touch of a button. Each column can therefore be used at any given location.

Full color touch screen control

The revolutionary **ebright Smart Control System** combines intuitive **ease of use** with maximum visual information about the lifting process. The main advantages:

- 7 " full color touch screen, even when wearing gloves
- User-configured options, such as choice of language, safety warnings and scheduled maintenance notifications
- All relevant information available at a glance
- Customizable ID-Key to prevent unauthorized operation
- Wireless Mesh network for optimal connectivity



Reliable hydraulic technology

- Long usable life of the column with minimal repair and maintenance, thanks to reduced friction
- Stringent testing before leaving the factory
- Manual lowering in case of a power outage
- Maximum protection of the cylinder and seal against damage

Adjustable lowering speed

If you need to lower the vehicle more slowly for precision placement of under carriage components, this is easily done with a single touch.

Power supply

The Stertil-Koni wireless mobile column lifts operate on 24 VDC and are easily recharged by means of a 110 VAC wall receptacle. The Stertil-Koni cabled mobile lifting columns operate on three phase at 208/230, 460/480, and 575 VAC, as well as single phase at 220 VAC.

Fast lifting and lowering

The ST 1075 only takes 75 seconds to reach its maximum lifting height of 73". This makes it one of the fastest mobile column lifts in the world.

Easy to move

Stertil-Koni mobile column lifts are indeed mobile, thanks to the synthetic roller wheels and hydraulic pallet jack mechanism with patented overload protection.

Safe working space

As an extra safety feature, we have also designed ample working space between the column and the vehicle. This ensures that the vehicle should not come into contact with the column.



Unique synchronization

The synchronization system is activated at a height difference of just 9/16". This ensures a safe and smooth-running lifting and lowering cycle, even in cases where the distribution of the vehicle load is extremely uneven.

Lifetime guarantee

The innovative synthetic runner wheel within the column is self-lubricating and comes with a lifetime parts guarantee.

Maximum flexibility of different vehicles

The standard length of the pick-up forks is 14". This means that it is also possible to lift vehicles with super single tires safely.

Well thought out in all aspects



MAX 32 LINKED
COLUMNS



ADJUSTABLE
LOWERING SPEED



OVERLOAD
PROTECTION



UNIQUE SYNCHRONIZATION
SYSTEM

Choice of controls

For operating the ST 1075 mobile column lifts, Stertil-Koni offers a choice of two control systems:

- Wireless ebright Smart Control System (FWF)
- Cabled Superior Control (FSF)

Wireless

The control panel on each column is equipped with the ebright Smart Control System, providing a clear high resolution touch screen. Additional information, such as the charging status of the battery, the exact lifting height

and the number of columns in the setup, can be read on this display. Equipped with the patented Multi Master System, which allows you to setup the columns in any order.

Superior

This control provides maximum flexibility with respect to the number of columns that can be applied. The columns communicate with each other via interconnection cables fitted with heavy-duty plugs at both ends.



○ High resolution 7" touch screen

○ Intuitive controls



ebright Features

SMART CONTROL SYSTEM

- High resolution 7" touch screen
- Owner/User configurable system with user ID key
 - Individual user settings for setting language and units of measure
 - Protection against unauthorized use, thanks to personalized ID key
- Maintenance notifications
- Visual display of maximum programmable lifting height
- Warning and failure information
- Operation manual available on-screen

- Tracking of specific operations and information codes
- Intuitive controls with actual data about the lift:
 - Indication for Single, All or Pair operation mode
 - Information about how many columns are in the set (up to 32 columns)
 - Actual lifting height displayed
 - Lowering speed can be manually adjusted on the touch screen
 - Battery status information
 - Customizable ID-Key to prevent unauthorized operation
- Wireless Mesh network with continuous active channel search offering optimal connectivity

Everything under control



Superior control for cabled version

Overview of ST 1075 types and controls

	ebright wireless ST 1075-FWF	superior cabled ST 1075-FSF
ebright Smart Control System with a control box on each individual mobile column	●	
Touch screen with important information about the system e.g. lifting height, battery status	●	
Superior control with a control box on each individual mobile column		●
Adjustable lowering speed for slow or normal lowering speed	●	●
Hydraulic pallet truck lifting mechanism with patented overload protection	●	●
Fixed fork, 14" long, suitable for super single tires	●	●
Fixed synthetic wheels that reduce the floor surface pressure	●	●

Technical specifications

Lifting capacity:	16,500 lbs
Lift system:	hydraulic lifting system with microprocessor-controlled synchronization
Lifting height:	maximum 73", automatic stop at the highest position
Lifting time:	75 seconds
Motor rating:	3 hp / 4 hp per column (Superior / Wireless)
Weight:	1,255 lbs column (Wireless)
Column height:	97"

Highest safety requirements

- ANSI/ALI-ALCTV certified (USA)
- CSA certified (Canada)
- CE certified (Europe)
- Independent mechanical locking system engages at 18" above finished floor. Locking pawl engaged by gravity. The locking system is always active, even when the column is turned off
- Locking profile with locking increments of just 1 3/8"
- Synchronization between the mobile column lifts starts at a height difference of 9/16"
- Each mobile column lift is equipped with a safety valve that monitors the system for sudden pressure loss – i.e. caused by leakage - during the entire lifting process
- Automatic overload protection
- Low voltage control panel
- Each system is equipped with dead man's switches
- Each individual mobile column lift is tested prior to leaving the factory
- Splash-proof electrical system (NEMA4)

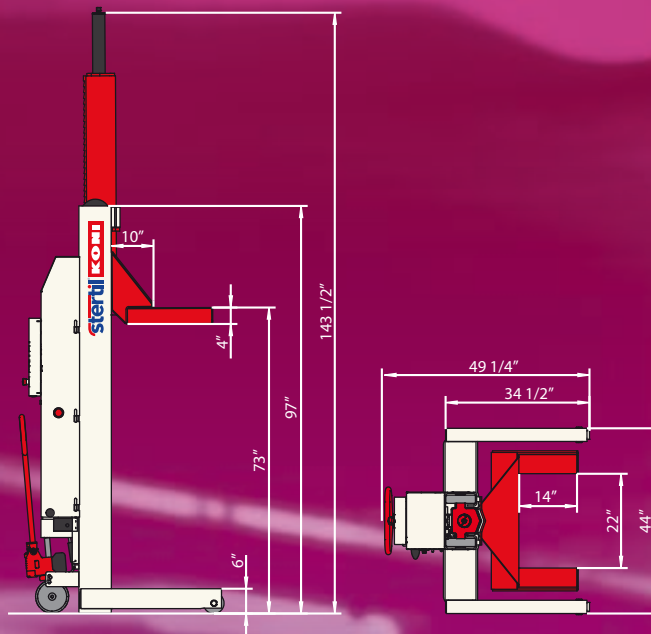

Accessories & options

Stertil-Koni offers an extensive package of accessories & options tailored to fit your specific needs. Optional products available include:

- LED lighting set
- Forklift adaptor set
- Various cross beams for lifting trailers and other specialty applications
- Wheel adaptors

More information?

For more information about the ST 1075, or any of Stertil-Koni's other top products, please do not hesitate to contact us. We will be pleased to assist you.

* Technical specifications are available at www.stertil-koni.com



Stertil-Koni U.S.A. Inc.
200 Log Canoe Circle
Stevensville, Maryland 21666
Tel. 410-643-9001
Toll free 800-336-6637
Fax 410-643-8901
www.stertil-koni.com
E-mail: lifts@stertil-koni.com