

sterti **KOMI**

FREEDOMLIFT



FREEDOM LIFT

HEAVY DUTY 2-POST LIFT

SK 2.16 / SK 2.16EFA

Capacities 16,000 lbs

- Symmetrical open floor design providing work and moving space in the workshop
- Smooth lifting/lowering synchronization utilizing Pulse Width Modulated (PWM) hydraulic valves
- Independent mechanical locking system with 1 1/4 inch increments starting 8 inches from floor level
- Fast lifting speed of 58 seconds
- Model SK 2.16 is executed with double telescopic support arms. The SK 2.16EFA is executed with extended flex arms.



STERIL
SUPERIOR SOLUTIONS BY
QUALITY PEOPLE

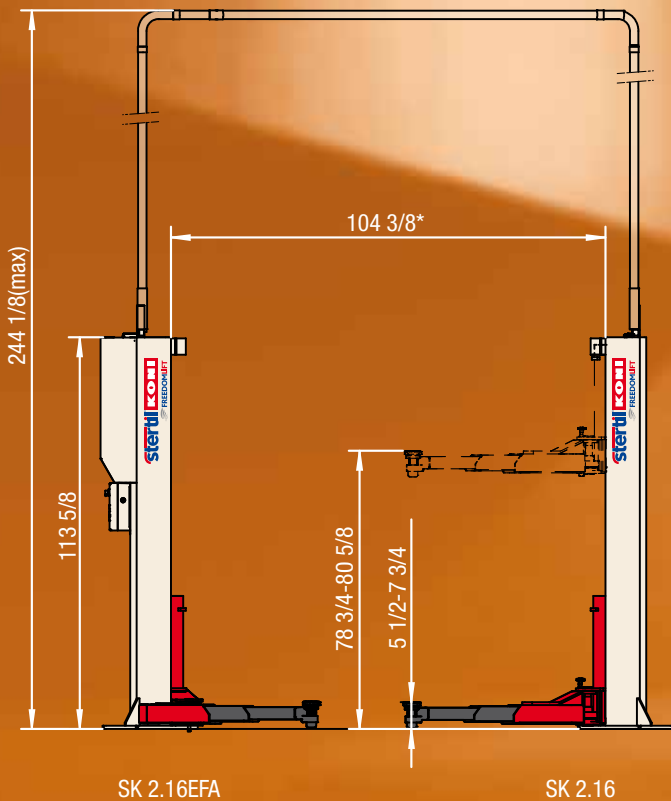
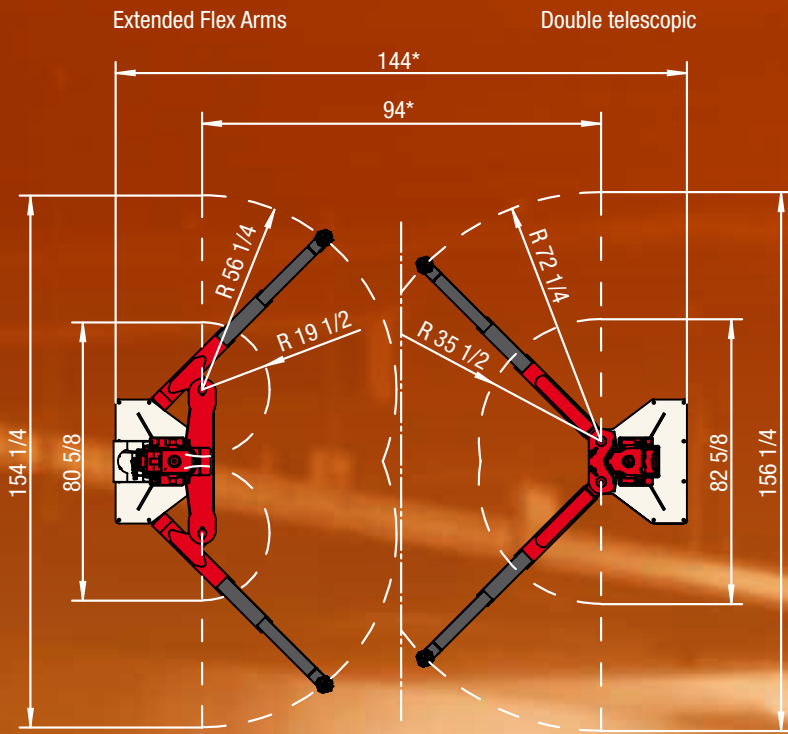

Model		SK 2.16	SK 2.16EFA
Lifting capacity		16,000 lbs	16,000 lbs
Lifting height		80 5/8"	80 5/8"
Min. pick-up height		5 1/2"	5 1/2"
Arm length (double telescopic)	min	35 1/2"	19 1/2"
	max	72 1/4"	56 1/4"
Lifting time		58 sec	58 sec
Motor power		5 hp	5 hp

For more information

For more or specific information about the Stertil-Koni FREEDOM LIFT or any of Stertil-Koni's other top products, please do not hesitate to contact us. We will be pleased to assist you.

* Flexible dimensions. Technical specifications are available at www.stertil-koni.com



Stertil-Koni U.S.A. Inc.
 200 Log Canoe Circle
 Stevensville, Maryland 21666
 Tel. 410-643-9001
 Toll free 800-336-6637
 Fax 410-643-8901
www.stertil-koni.com
 E-mail: lifts@stertil-koni.com

